

General Description

The FA-DX (fahrenheit) and FA-DX-AAB (celsius) FreezeAlarm™ monitors temperature, power status, security or an external contact, and offers remote switch control capability. Upon an alarm condition, the FreezeAlarm™ automatically dials up to three phone numbers with a voice message. Current temperature and alarm conditions can be checked by calling the FreezeAlarm™ from any remote location.

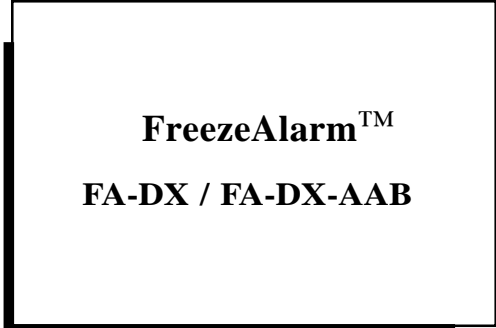

Applications

Applications include remote temperature, power and security monitoring of refrigeration, heating and air conditioning equipment for buildings (homes, cabins and commercial buildings) and monitoring of any relay output system or sensor. The remote switch control feature can be used to control thermostats or equipment from any Touch Tone™ phone (additional parts and labor may be needed).

Features

- Adjustable high & low temperature alarm setpoints
- Three telephone number call out, up to 16 digits each
- Paging feature - any or all of the call-to numbers can be to a digital pager
- Power loss call out alarm
- Low battery call out alarm
- Remote access to programming menu and current condition status
- Monitors an open contact
- Remote control switch relay
- Location identification number
- Custom voice message recording
- Selectable 15 minute or 2 hour call out interval
- Selectable 10 or 3 ring call out
- Security coded access to programming menu
- Dials out in pulse or tone
- LED status indicators
- Battery back-up (9 volt-not included)

Specifications

Power requirements: Plugs into standard 110 VAC outlet (plug-in wall transformer with six foot long cord included)

Sensor: Semi-conductor sensor with 1.75" x .25" nickel plated copper cap and three foot cord

Operating range of sensor: -49° to 199°F (-45° to 93°C)

Accuracy: ±2°F (±2°C)

Remote switch: SPDT, 10 amps 24 volts resistive

Ambient temperature range: 32° to 140°F (0° to 60°C)

Humidity: 90% non-condensing

Weight: 3.0 pounds (1.4kg)

Dimensions

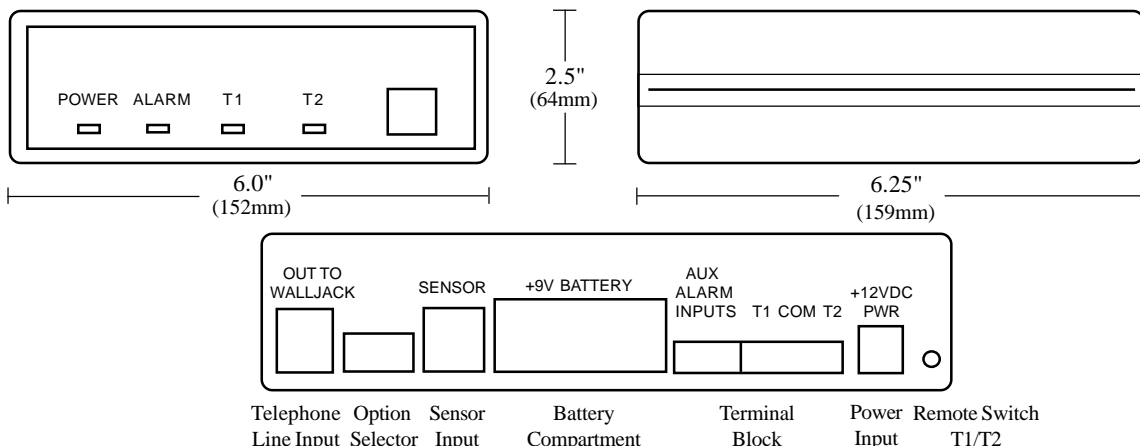

Installation

IMPORTANT: It is critical that the FreezeAlarm™ be tested at the location of actual use, along with actual call-out to destination, since local and long distance telephone lines and systems vary and may affect performance.

1. **Before Starting:** Please read the **Warranty** information before using this product.
2. Connect temperature sensor to the back of the FreezeAlarm™.
3. Connect the auxiliary alarm system (i.e. motion detector, etc.), and relay switching equipment (if applicable) to ports in back of unit (additional installation by a licensed professional may be required).
4. Connect the plug-in power supply to the +12VDC port on the rear of the unit.
5. Plug the power supply into a 110 VAC wall outlet.
6. Install a 9 volt alkaline battery (not included) in the back of the unit. If the battery is not installed within 5 minutes of the wall power, a low battery alarm will occur.
7. Plug any standard Touch Tone™ telephone into the telephone jack (labeled "phone") located on the front panel of the FreezeAlarm™.
8. Follow the procedures in the **Programming Instructions** described below to program unit.
9. Select and set dip switch options on back of unit – see **Dip switch table (page 6)**.
10. After programming, disconnect the programming phone and connect one end of the 7' phone cord provided to the OUT TO WALL JACK port on the back of the unit, and the other end to a standard telephone jack.

Programming Instructions

IMPORTANT: When the FreezeAlarm™ is first powered up it will not check any of the alarm conditions for 5 minutes. After this initial 5 minute start-up period the alarm conditions will be checked continuously. The battery voltage will be checked every 10 minutes.

When the programming phone is picked up the alarm conditions are checked and any alarms present are reported. If the callout is active and has not been disabled, the menu will give you the option of disabling the alarm call-out. The FreezeAlarm™ is programmed by following a series of menu driven voice commands and can be reprogrammed remotely or locally (at unit) from any Touch Tone™ telephone.

The following data must be programmed into the FreezeAlarm™:

- A. TEMPERATURE ALARM SETPOINTS – high and low temperatures at which an alarm call-out will be initiated.
- B. CALL OUT TELEPHONE NUMBERS – up to three telephone numbers to be called in succession during an alarm condition.
- C. SECURITY/LOCATION CODE – four-digit code used to gain access to the main menu, or to disable the unit and identify its location.

After connecting a Touch Tone™ telephone to the front receiver port, lift the phone receiver and follow the verbal prompts. The FreezeAlarm™ will say:

"You are now in the main menu:"

"To review or program call out telephone number menu, press 1."

"To review or program the pager display number, press 2."

"For auxiliary alarm status, press 3."

"To review the current temperature, press 4."

"To review or program the temperature alarm setpoint menu, press 5."

"For the position of the remote switch, press 6."

"To review or program the security code, press 7."

"For the battery status, press 8."

"For the power status, press 9."

"To record a message, press 0."

On the following page the entire menu selection of the FreezeAlarm™ is shown. You can see all of the sub-menus that will be played when any of the main menu selections are pressed.

NOTE: If the FreezeAlarm™ does not recognize an entry, you will hear "invalid entry" and the menu selections will be replayed. Re-enter your menu selection within 15 seconds to continue with the programming sequence.

IMPORTANT: After programming, disconnect your telephone from the PHONE receiver port on the front of the FreezeAlarm™. The phone can not be used for outgoing phone calls while connected to the FreezeAlarm™.

The menu structure of the FreezeAlarm™.

If a “1” is pressed:

To review or program call out telephone number one press one

Call out telephone number two press two

Call out telephone number three press three

To return to the main menu press four

If you press “1”, “2” or “3”

Call out telephone number (1 / 2 / 3) is now xxxxxx

To change press zero

To return to call out telephone number menu press one

Otherwise to return to the main menu press two

If a “2” is pressed:

The pager display number is xxxxxx

To change press zero

Otherwise to return to the main menu press one

If a “3” is pressed:

[aux custom message] auxiliary alarm (is in / is not in) an emergency condition

to return to the main menu press one otherwise hangup

If a “4” is pressed:

The current temperature is xxx degrees

To return to the main menu press one otherwise hangup

If a “5” is pressed:

To review or program the high temperature alarm set point press one

To review of program the low temperature alarm set point press two

To return to the main menu press three

If you press “1” or “2”

(the high / the low) temperature alarm set point is now xxx degrees

To change (the high / the low) temperature alarm set point press zero

To return to the temperature alarm set point menu press one

Otherwise to return to the main menu press two

If a “6” is pressed:

The position of the remote switch is currently (T1 / T2)

To change the position of the remote switch to (T2 / T1) press zero

Otherwise to return to the main menu press one

If a “7” is pressed:

The security code is xxxx

To change the security code press zero

Otherwise to return to the main menu press one

If a “8” is pressed:

The battery is now xx.xx volts

The battery (is in / is not in) an emergency condition

To return to the main menu press on otherwise hangup

If a “9” is pressed:

The power is (off / on) to return to the main menu press on otherwise hangup

If a “0” is pressed:

Greeting message is now [custom message] to change press one

Auxiliary alarm message is now [aux custom message] to change press two

To return to the main menu press three

MENU DESCRIPTIONS

- CALL OUT TELEPHONE NUMBERS:** Follow verbal prompts to change call-out telephone numbers. You may enter the star key to leave an entry blank (no number). After call-out telephone numbers are programmed, press "1" to return to Call-Out Telephone number menu. Once in the Call-Out Telephone Number Menu, press "4" to return to the main menu.
- PAGER DISPLAY NUMBER:** If you program your FreezeAlarm™ to call a pager, you need to enter a pager display number. This number will appear on your digital pager during an alarm. You could select the location ID, the phone number for the FreezeAlarm™ unit, or any other combination of numbers up to 32 digits. (If your paging service requires a pause before the numbers are entered, include a pound sign (#) before the pager display number. Each (#) entered delivers a 5-second pause. Test before using.) If you enter a pager display number and also receive a telephone call from the FreezeAlarm™ during the alarm, you will hear the Touch Tones of the pager display number before the voice message begins. A "#" sign will be played as "press."
- AUXILIARY ALARM STATUS:** Monitors an open external contact from your auxiliary relay device. Reports the status of the external contact. If the contact closes, an auxiliary alarm will be reported.
- CURRENT TEMPERATURE:** Reports the current temperature of the sensor.
- TEMPERATURE ALARM SETPOINTS:** The temperature alarm setpoints are the high and low temperatures at which the FreezeAlarm™ will initiate an alarm call to your programmed telephone numbers. Both setpoints need to be programmed.
- REMOTE RELAY SWITCH:** The remote relay switch (single pole/double throw) can be used to manually switch equipment over the phone. The state of the relay can be switched by pushing the remote switch button on the back of the FreezeAlarm™. Follow verbal prompts to activate the relay. The FreezeAlarm™ will report the position of the remote relay switch.
- SECURITY/LOCATION CODE:** The security code is factory set at "9999". Follow verbal prompts to change the security code. Security code is also the location ID code.
- BATTERY STATUS:** The low battery status alarm will occur at 7 volts. **Important:** Replace battery annually, or when battery voltage drops below 7 volts. The battery voltage will be checked every 10 minutes.
- POWER STATUS:** The FreezeAlarm™ will report that the "power is off" in the event of an electrical power failure. This feature can be enabled and disabled via the DIP switch. The duration of the power outage detection can be set to hour or zero minutes via the DIP switch.
- RECORD A MESSAGE:** A custom greeting message and an auxiliary alarm message may be recorded. Each message can be up to 10 seconds long. When the recording is done press the starkey (*). The greeting message will be used in the following context "Hello, this is [greeting message] . . ." The auxiliary alarm message can be used to specify the device attached to the auxiliary alarm inputs. (ex: "water detection sensor")

UPON ALARM

The FreezeAlarm™ will call out and play "Hello, this is [custom message]" then one or more of the following messages.

"There is a temperature alarm emergency at location (your four digit security/location code). Help is needed immediately!"
AND/OR

"There is an auxiliary alarm emergency at location (your four digit security/location code). Help is needed immediately!"
AND/OR

"There is a power alarm emergency at location (your four digit security/location code). Help is needed immediately!"
AND/OR

"There is a battery alarm emergency at location (your four digit security/location code). Help is needed immediately!"

The alarm message(s) is repeated once, followed by:

"To disable the alarm call out, enter your four digit security code followed by star key."

You must enter the correct security code within 15 seconds or the FreezeAlarm™ will hang up and call again in the selected interval (15 minutes or 2 hours). If you enter the correct security code within 15 seconds you will hear:

"The alarm call-out is now disabled. To return to main menu, press 1, otherwise hang up."

You now have the option of returning to the main menu to review or change the system data.

CALLING THE FREEZE ALARM FROM A REMOTE LOCATION

When called from a remote location using a Touch Tone™ phone, the FreezeAlarm™ will answer after five rings and you will hear:

"Enter the security code followed by the star key."

If you enter the correct security code within 15 seconds, and the FreezeAlarm™ is not in alarm, you will enter the main menu and hear:

"You are now in the main menu. To review or program. . ."

If the FreezeAlarm™ is in alarm, you will hear one of the four alarm messages described in **Upon Alarm** above. The alarm message is repeated once, followed by: *"To disable the alarm call out, press 0. Otherwise, to return to the main menu, press 1."*

IMPORTANT INFORMATION

- Temperature alarm delay feature: If dip switch #6 is placed in the UP position, the FreezeAlarm™ will delay 45 minutes during a temperature alarm only. A temperature alarm condition must be present for 45 minutes before unit will call out.
- Power alarm delay feature: The power alarm delay is selectable from either 1 hour or 0 minutes.
- Reset button: The reset button on back of unit will switch the remote relay to the opposite setting.
- Using FreezeAlarm™ on the same phone line as telephone: The FreezeAlarm™ does not require a dedicated phone line and can share a phone jack with a telephone by using a dual plug adapter (not included). Caution: The FreezeAlarm™ will not work on a PBX or multi-line systems, or a party line.
- Phone answering machines at the occupied (call to) location: To avoid unwanted long distance phone charges between the FreezeAlarm™ and a remote answering machine when you are not at home, set your answering machine to pick up after four rings or higher and move dip switch #5 on the rear of the FreezeAlarm™ to the UP position. This will cause the FreezeAlarm™ to hang up after three rings, preventing the answering machine from picking up the alarm call. **Caution: Because of normal connection delays in long distance calls, unit may hang up before three rings are heard at call-to location. Test thoroughly!** If dip switch #3 is in the DOWN position, the FreezeAlarm™ will hang up after ten rings. Depending on the length of your greeting, the answering machine may record a portion of the alarm message.
- Phone answering machines at the same location as the FreezeAlarm™: An answering machine normally will pick up a call before the FreezeAlarm™. To gain access to the FreezeAlarm™ when used with an answering machine, set the answering machine's ring selector at four. Call the FreezeAlarm's phone number and hang up before the answering machine answers. Call back again to accumulate 5 rings within 3 minutes and the FreezeAlarm™ will pick up your call.
- Monitoring multiple Freeze Alarms using identification number: Upon alarm, the FreezeAlarm™ calls its programmed telephone numbers and announces the location of the alarm, with the custom message and the SECURITY CODE as a location identification number. This enables you to monitor and identify an infinite number of FreezeAlarm™ locations.
- Using the Remote Relay Switch: The remote relay switch can be used to switch equipment or thermostats over the phone. When the power goes out and the FreezeAlarm™ is being powered off the battery, the relay will be in the T2 position. Because types of equipment and systems vary, it is strongly recommended that a licensed professional perform the installation and wiring needed for your specific application.
- Alarm Call-out: The FreezeAlarm™ will continue to call-out with an alarm until disabled, even if alarm conditions have been corrected.
- Surge Protection: Lightning surge protection is recommended for the telephone line and the power.

Dip switch table:

Factory settings are in the DOWN position.

Switch #	Function	Settings	
1	Pulse / Tone dial out	UP = pulse	DOWN = tone
2	1 hour power alarm delay off / on	UP = immediate	DOWN = on
3	Power alarm call out feature on / off	UP = on	DOWN = off
4	2 hour / 15 minute callout frequency	UP = 2hour	DOWN = 15min
5	Select between 3 or 10 ring call out	UP = 3	DOWN = 10
6	45 minute temperature alarm delay on / off	UP = on	DOWN = immediate

Troubleshooting

Problem

Solution

- | | |
|---|---|
| <p>1. Unit does not function</p> <p>2. Phone does not ring at "call-to" location</p> <p>3. Cannot access FreezeAlarm™ (same location)</p> <p>4. Cannot access FreezeAlarm™ (remote location)</p> <p>5. Receiving false alarms</p> <p>6. Temperature reading -40°F</p> | <p>Check power supply and phone line service.</p> <p>Review telephone number and reprogram. Change Dip Switch #5 to the ten ring position (DOWN).</p> <p>Make sure Touch Tone™ telephone is plugged into front face plate. Try a different phone.</p> <p>Make sure Touch Tone™ telephone is being used. Check FreezeAlarm™ power and telephone connections. Try a different phone. Verify security code.</p> <p>Do not place temperature sensor near heat vents, drafts, or other areas that do not represent the ambient temperature being monitored. Raise or lower thermostat accordingly.</p> <p>Check sensor connection to correct jack.</p> |
|---|---|

Ordering Information

Please use the following example when ordering:

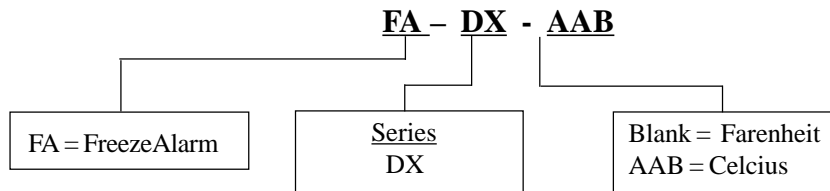

Other models are available: FA-I FreezeAlarm™ and FA-D FreezeAlarm™

Custom Design & Modifications

In addition to standard models, Control Products specializes in complete custom design of electronic controls. Modifications of our standard controls are also available. Please consult factory for more information.

Limited Warranty

Limited Warranty:

1. Warrantor: Dealer, Distributor, Retailer, Manufacturer
2. Warranty and Remedy:

We believe this is a very fine product. Over the years, we have received many calls and letters from folks with thanks and stories on how our product alerted them to a potentially costly freeze-up. We have also heard from a few unhappy folks complaining that this product did not alert them during a freeze-up. Although we take extreme pride in producing and testing a product that will function properly, we cannot guaranty that there will never be a defective unit, or that a unit will function on all of the thousands of phone lines and communication equipment in existence. For this reason, **it must be clear that the Warrantors are not insuring your premises or guaranteeing that there will not be damage to your person or property if you use this Product.** If you are not comfortable with our Limited Warranty, or completely satisfied with the Product, we encourage you to return the unused Product for a full refund. Thank you for your understanding.

One Year Limited Warranty - Control Products, Inc. warrants its products to be free from defects in material and workmanship under normal use for one year, and is not responsible for consequential damages or installation costs of any nature. In the event that the Product does not conform to this Warranty at any time during the period of one year from original purchase date, Warrantor will repair the defect and return it to you at no charge. **IMPORTANT: The Warranty is limited to replacement of the Product ONLY. Secondly, because every phone line differs, we stongly encourage you to fully test this Product in its actual application. This should include a full test, involving the Product actually dialing to its designated location and someone verifying the proper response.**

This Warranty shall terminate and be of no further effect at the time the Product is 1) damaged by extraneous causes such as fire, water, lightning, etc., or not maintained as reasonable and necessary; 2) modified; 3) improperly installed; 4) repaired by someone other than the Warrantor; 5) used in a manner or purpose for which the Product was not intended.

WARRANTORS' OBLIGATION UNDER THIS WARRANTY IS LIMITED TO REPAIR OR REPLACEMENT OF THE PRODUCT ONLY. THIS WARRANTY DOES NOT COVER PAYMENT OR PROVIDE FOR THE REIMBURSEMENT OF PAYMENT FOR INCIDENTAL OR CONSEQUENTIAL DAMAGES.

It must be clear that the Warrantors are not insuring your premises or guaranteeing that there will not be damage to your person or property if you use this Product. The Warrantors shall not be liable under any circumstances for damage to your person or property or some other person or that person's property by reason of the sale or use of this Product, or its failure to operate in the manner in which it is designed. The Warrantors' liability, if any, shall be limited to the original cost of the Product only. Use of this Product is at your own risk.

3. Procedures for Obtaining Performance for Warranty:

In the event that the Product does not conform to this Warranty, the Product should be shipped or delivered freight prepaid to a Warrantor with evidence of original purchase. **If in any way you are not comfortable with the product or its Limited Warranty, we encourage you return it unused for a full refund.**

Thermostat Connection

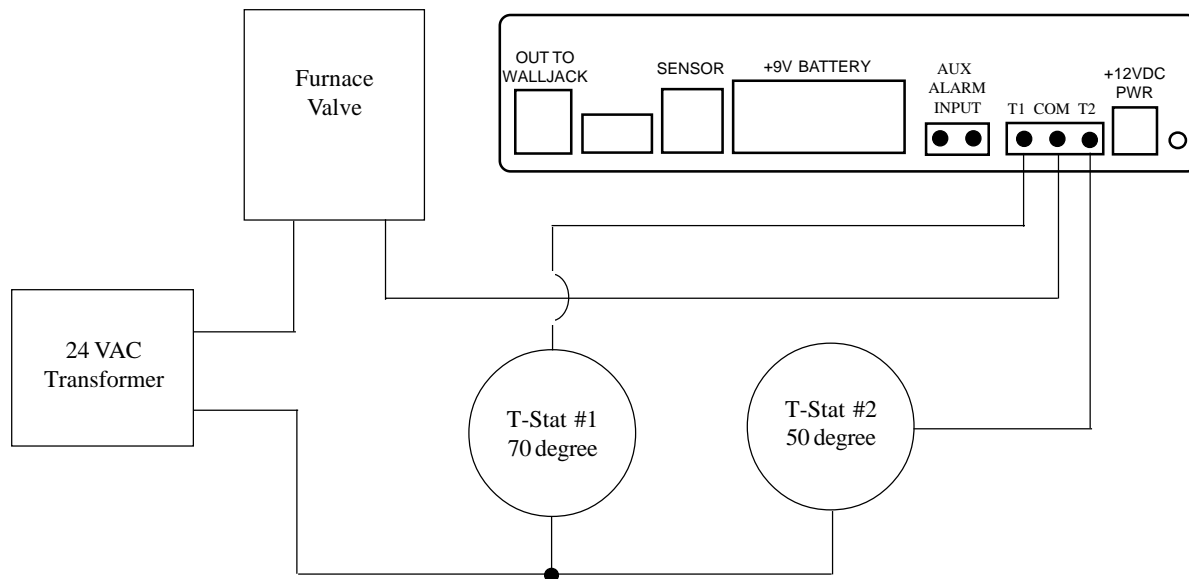

The wiring diagram above is for a typical 24 volt AC system. Other systems or configurations are possible. Please check with a licensed contractor for proper installation. The relay is acting as a two-position switch between the 24 volt power supply and the thermostats (T-stats). T-stat #2 will be controlling the "unoccupied" temperature. In this application, you are simply switching 24 volt power between the two thermostats.

FCC Regulations

This equipment complies with Part 68 of the FCC Rules. On the bottom of this equipment is a label that contains among other information the FCC Registration Number and Ringer Equivalence Number (REN) for this equipment. If requested this information must be given to the telephone company.

The REN is useful to determine the quantity of devices you may connect to your telephone line and still have all of those devices ring when your number is called. In most but not all areas the sum of the REN's of all devices connected to one line should not exceed five (5.0). To be certain of the number of devices you may connect to your line as determined by the REN, you should contact you local telephone company to determine the maximum REN for your calling area.

If your telephone equipment causes harm to the telephone network the telephone company may discontinue your service temporarily. If possible they will notify you in advance. If advance notice is not practical, you will be notified as soon as possible. You will be informed of your right to file a complaint with the FCC.

Your telephone company may make changes in its facilities, equipment, operations or procedures that could affect the proper functioning of your equipment. If they do you will be notified in advance to give you an opportunity to maintain uninterrupted telephone service.

If you experience trouble with this telephone equipment, please contact Control Products, Inc. at 952-448-2217 for information on obtaining service or repairs. The telephone company may ask that you disconnect this equipment from the network until the problem has been corrected or until you are sure that the equipment is not malfunctioning.

This equipment may not be used on coin service provided by the telephone company. Connection to party lines is subject to state tariffs. Contact your state public utility commission or corporation commission for information.

WHEN PROGRAMMING EMERGENCY NUMBERS AND (OR) MAKING TEST CALLS TO EMERGENCY NUMBERS:

- 1) Remain on the line and briefly explain to the dispatcher the reason for the call.
- 2) Perform such activities in the off-peak hours, such as early morning or late evening.